



Integrated Metadata Model for Radar Sensors

Anthony Galassi, Chair
Metadata Profile Working Group
May 2008
ISO TC211 Standards in Action Workshop





Agenda

- MPWG
- Radar Image Metadata Work
- Results and Future Effort
- Summary



GEOINT Standards Community



Geospatial Intelligence Standards Working Group
Chair: Mark DeMulder, NGA/OCIO
DoD/IC Forum for Standardization Activities

DoD IT Standards Registry (DISR)

GWG Focus Groups

- NITFS Technical Board (NTB)
- Motion Imagery Standards Board (MISB)
- Community Sensor Model Working Group (CSMWG)
- GEOINT Reporting Focus Group (RFG)
- Geographic Portrayal Focus Group (PFG)
- Metadata Focus Group (MFG)
- Information Transfer & Services Architecture Focus Group (ITSA)
- Application Schemas for Feature Encoding Focus Group (ASFE)

NITFS Technical Board (NTB)

Metadata Profile Working Group (MPWG)

Community Representation-Subject Matter Experts



MPWG Goal

The MPWG envisions an enterprise that supports a seamless, unified common operating picture. A community-wide, physics-based, metadata model will result in compatible products across the enterprise for the processes common to multiple sensors. By capturing physics common to multiple sensors, we enable interoperability of components throughout our architectures.

GWG Web Site Link: <http://www.gwg.nga.mil/>



Sensor (Imagery) Geospatial Metadata Levels

S (Sensor)

ACTIVE

PASSIVE

**Non-Scanning
Non-Imaging**

**Scanning
Imaging**

Non-Scanning

**Scanning
Imaging**

- Microwave Radiometer
- Microwave Altimeter
- Laser Distance Meter

- Image Plane Scanning
Passive Range Array
- Object Plane Scanning
Real Aperture Radar

- Synthetic Aperture Radar (SAR)

- Cameras
 - Microwave Radiometer
- (examples not sorted for these purposes)*

 Mandatory Metadata

 Levels of Metadata

Diagram adapted from Specific Sensor Geospatial Dataset in NSG Geospatial Core Metadata Profile (NGCMP) for context purposes



Sources of Remote Sensor Data

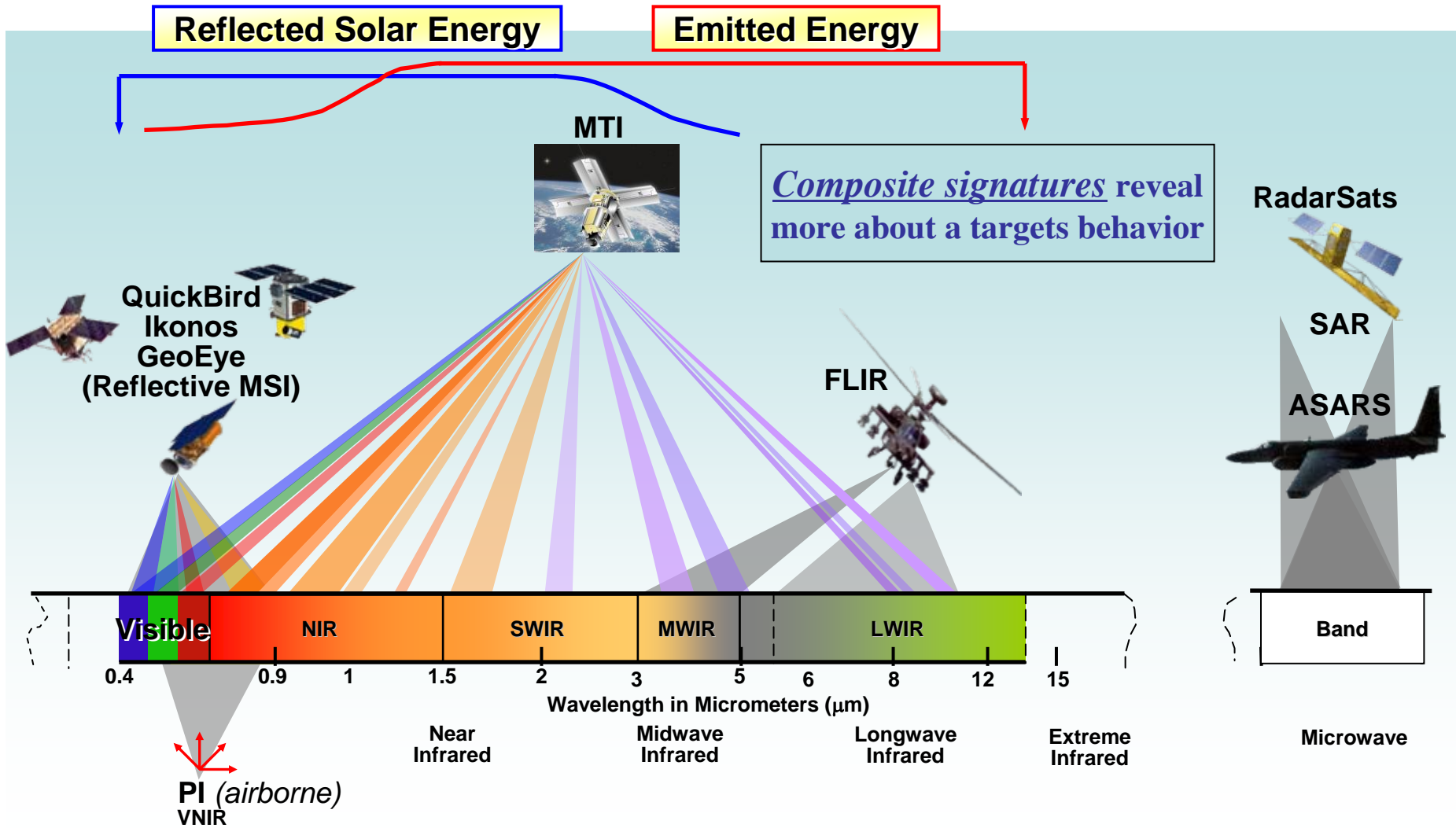

Target Signatures & Search Cueing

Slide created by NGA/IID and NGA/PL
MTI – Multi spectral Thermal Imager (DOE)



MPWG Radar Sensor Work

- **Harmonization of metadata across current sensor programs**
- **Publish standards that include a data dictionary of the harmonized metadata**
- **Enable common exploitation environment**
 - **data products, metadata, & tools**
- **Finish Data Model**
- **Finish Schemas**



What are SAR Products?

Processed SAR data

(SAR: Synthetic Aperture RADAR)

examples:

detected image

dynamic image

coherent change detection

color multiview

other ...



Radar Metadata Focus

Engineer the *Metadata* :

- *from* the sensor platform
through the exploitation environment
- *inherit, augment, delete* metadata
- *maintain* correct metadata for every process
- *result* in multiple data products



How is the SAR Metadata Used?

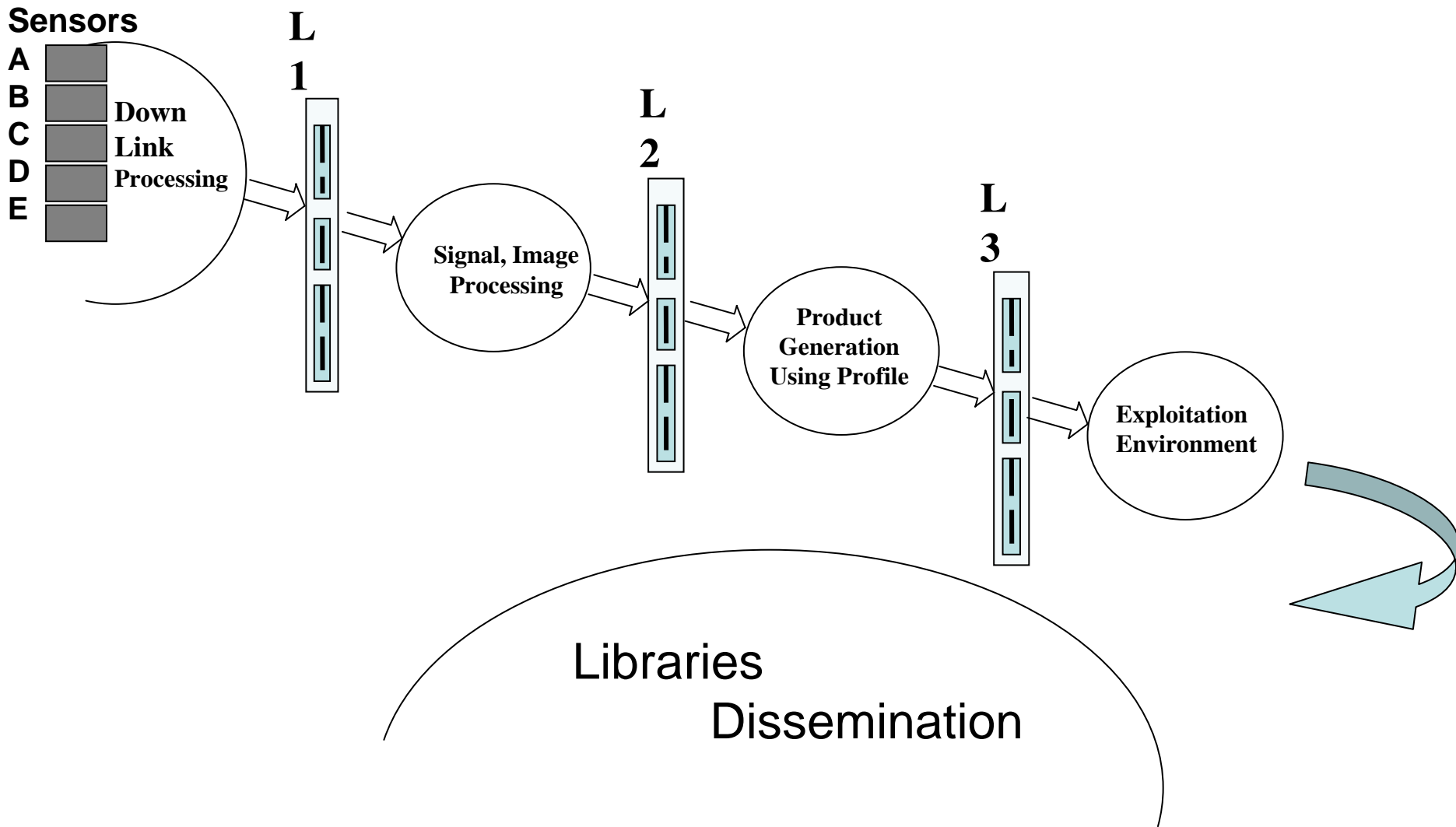



Product Enabling Metadata

Product: **Coherent Change Detection (CCD)**

INPUT: Level 2 Data - Paired Images:

Image Data: **complex compressed**

Metadata: collected area, time
azimuth & graze angles
bandwidth, frequency, modulation

OUTPUT: Level 3 Product - CCD:

Image Data: **pixel correlation map**

Metadata: area & registration points
time, azimuth, & graze angle deltas
intersecting bandwidths

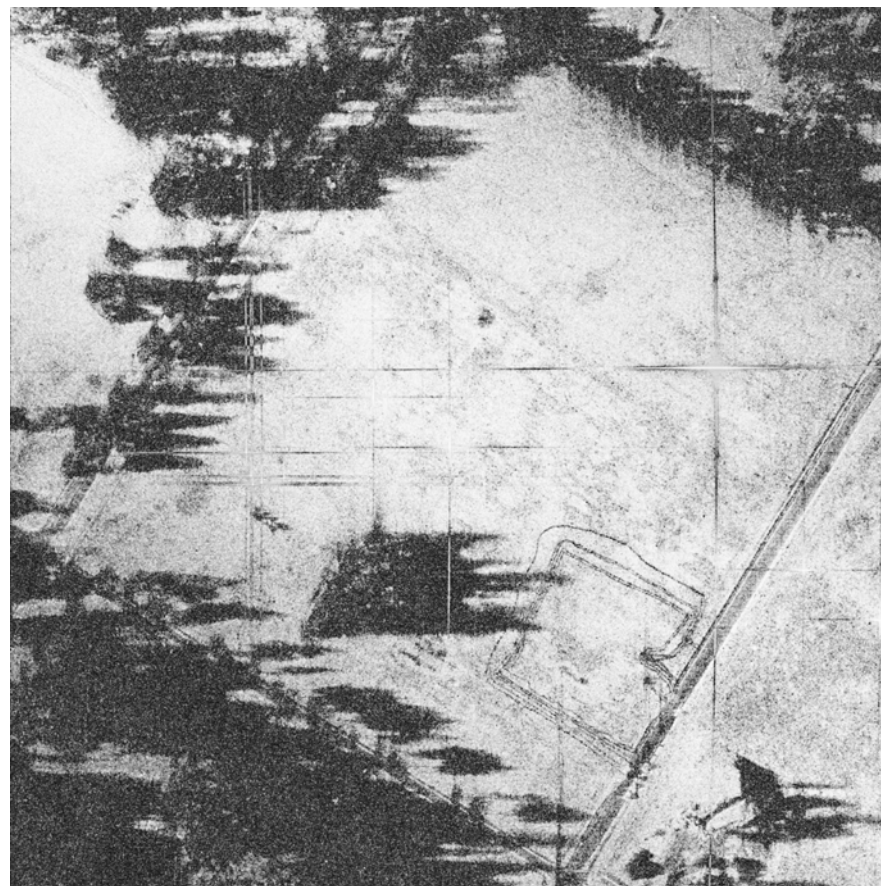



SAR Metadata Management

Metadata is inherited, augmented, deleted through the processing chain

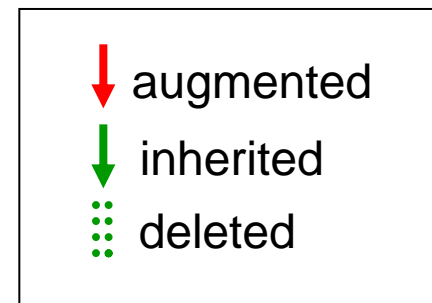
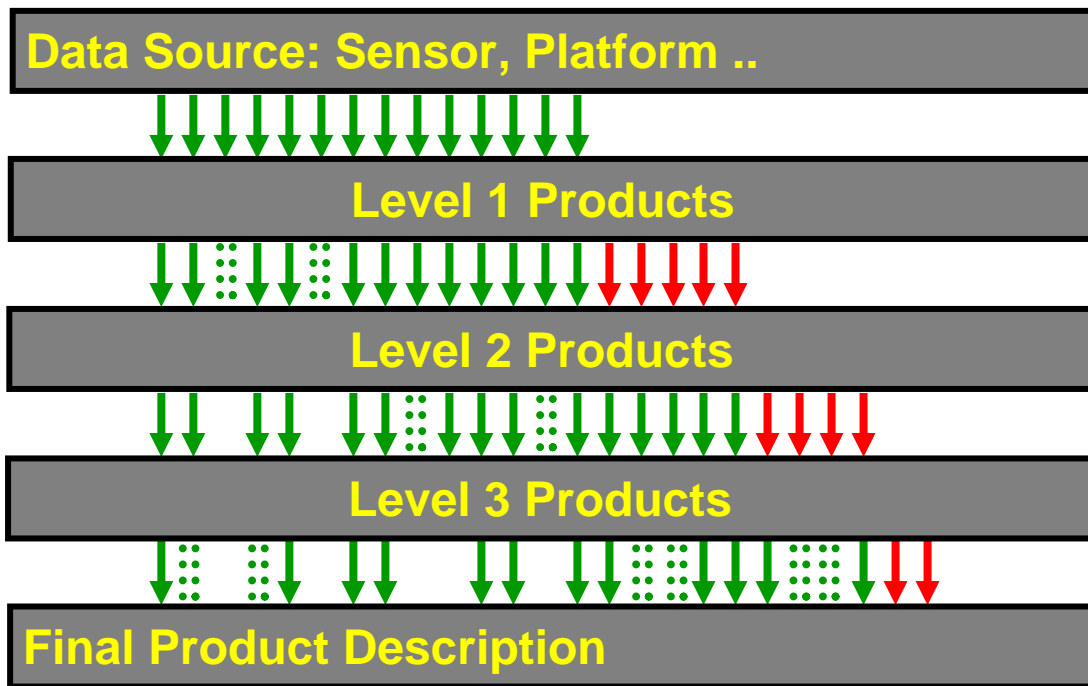



SAR Metadata Management

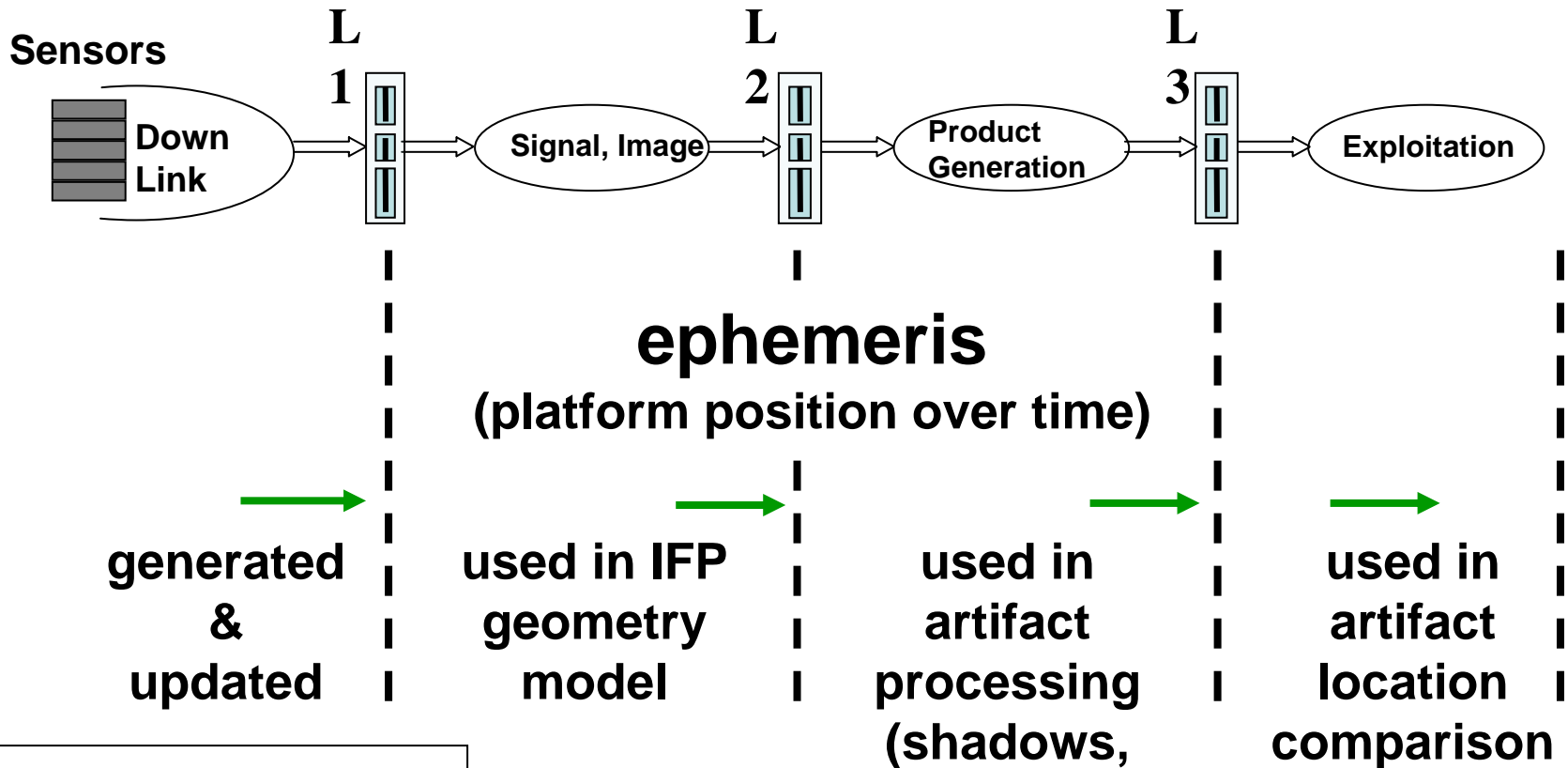

	augmented
	inherited
	deleted



SAR Metadata Management

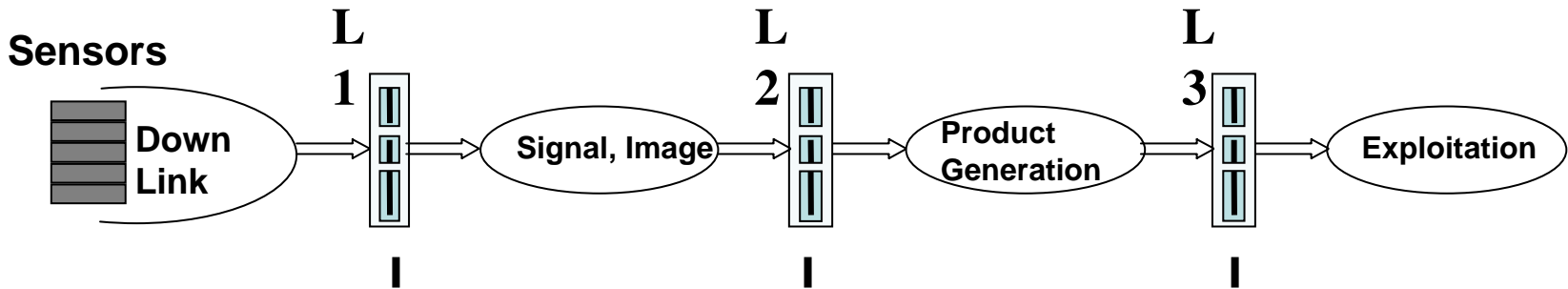

waveform parameters
 (transmitted/received signal form)

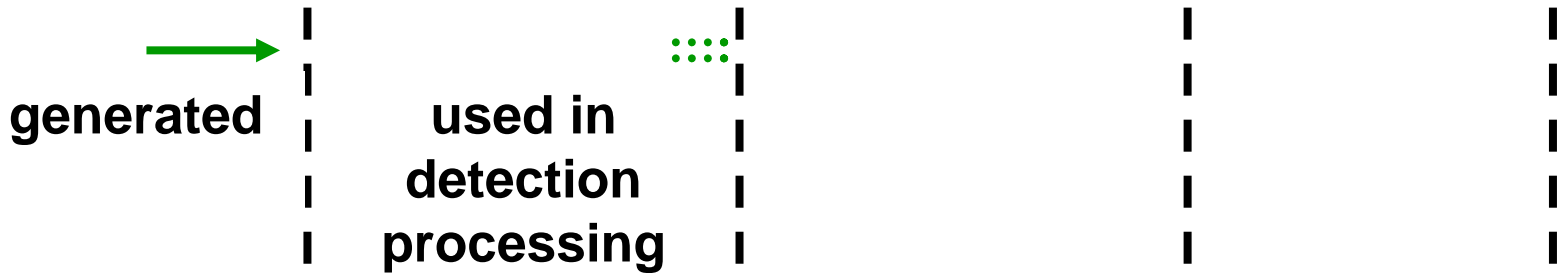

- augmented
- inherited
- ⋮ deleted



SAR Metadata Management

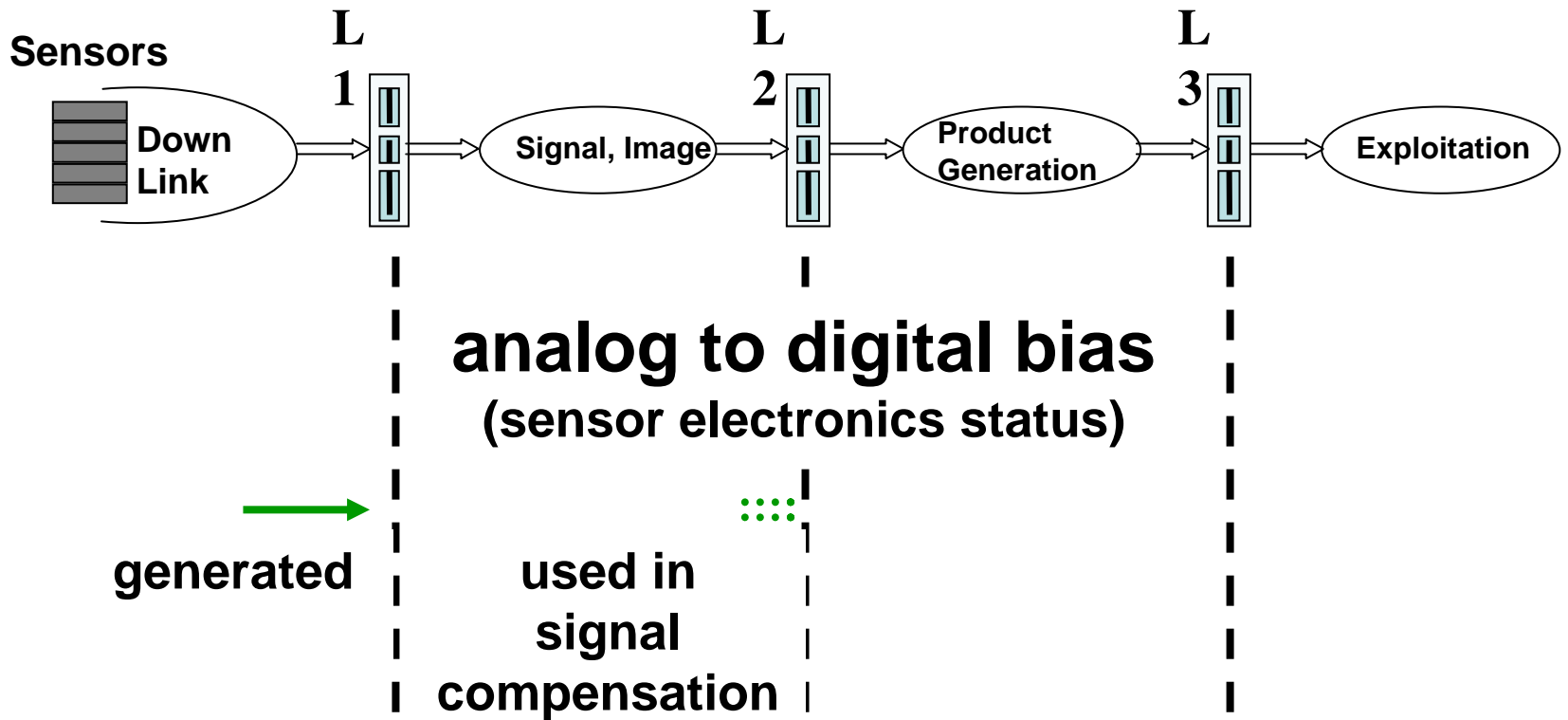

- augmented
- inherited
- ⋮ deleted



SAR Metadata Management

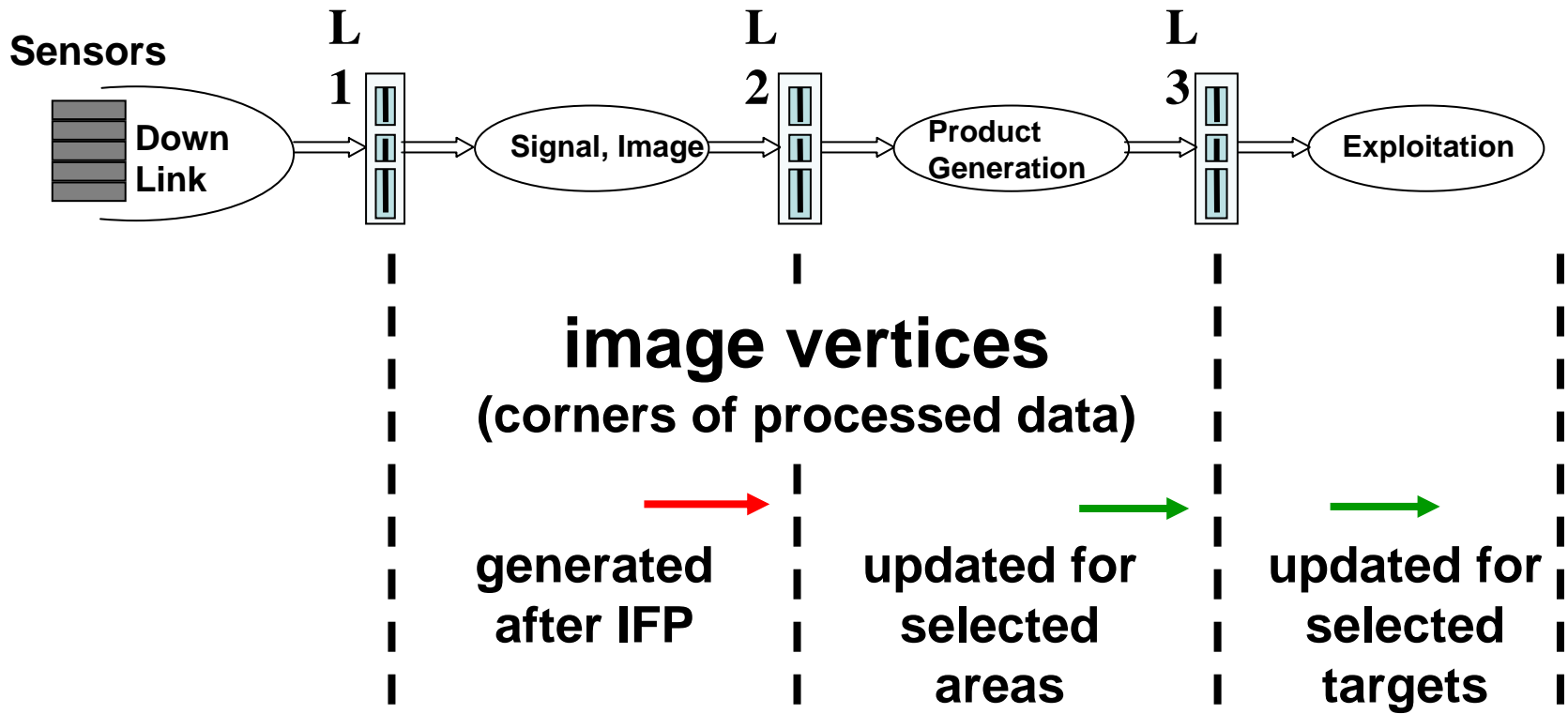

- augmented
- inherited
- ⋮ deleted



SAR Metadata Management

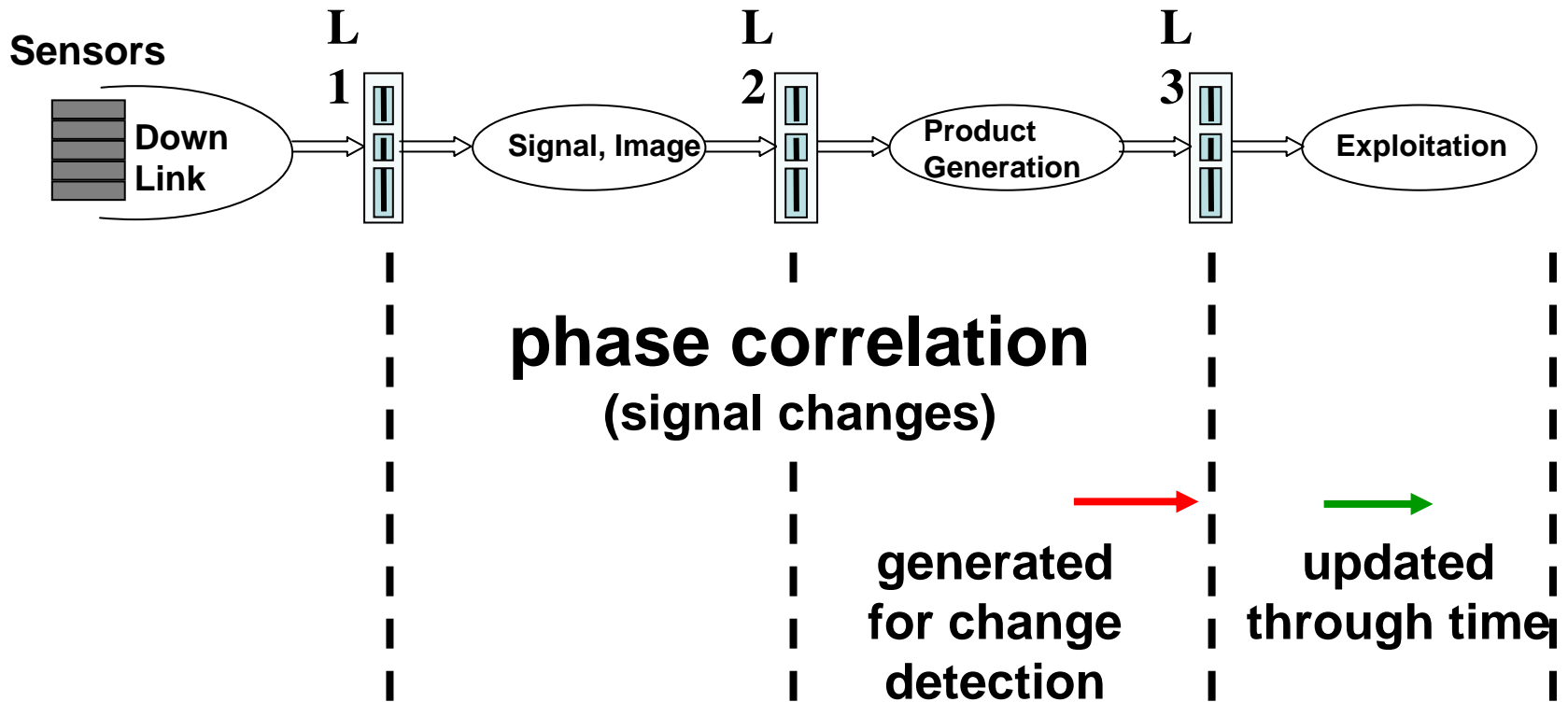

- augmented
- inherited
- ⋮ deleted



SAR Metadata Management

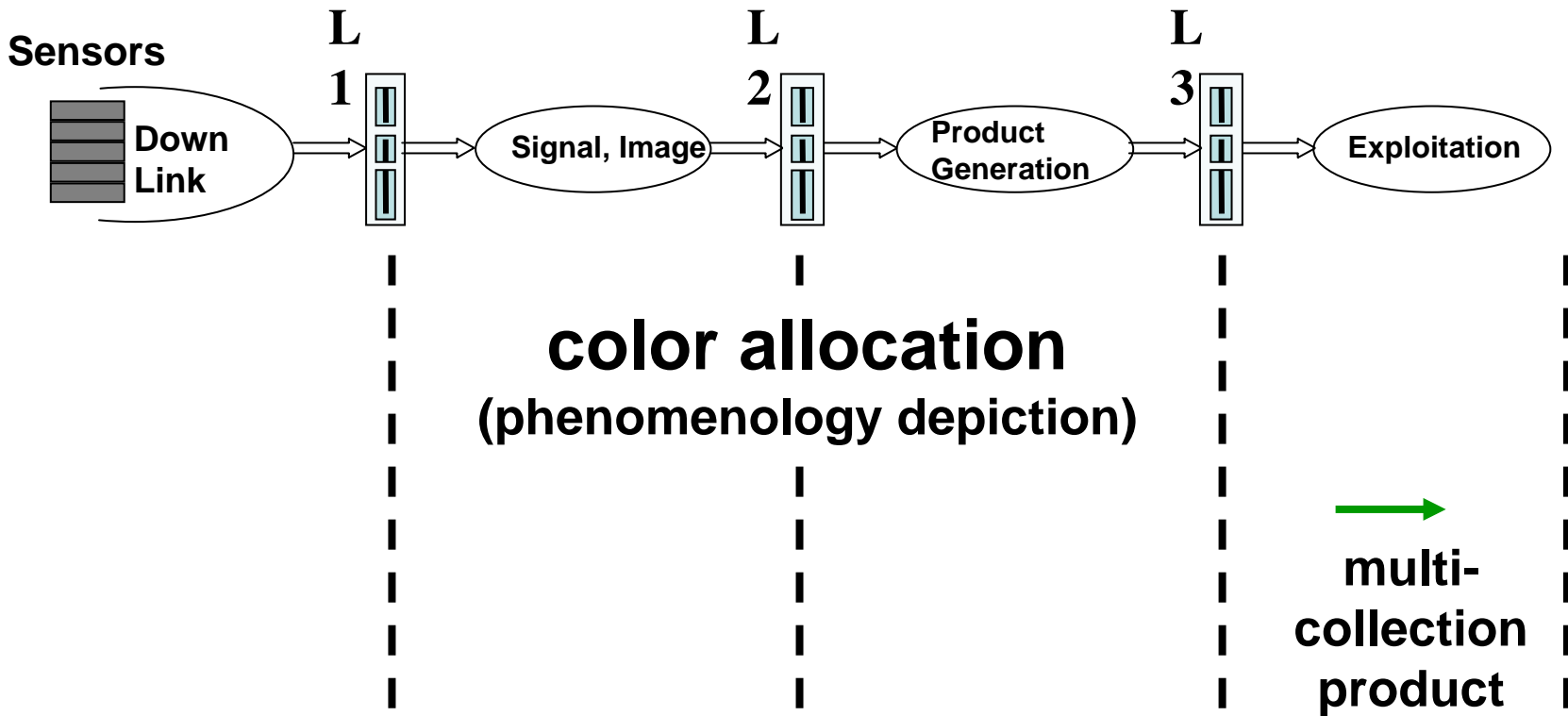

- augmented
- inherited
- ⋮ deleted



Multiple Metadata Formulations

The need for harmonization
example:

Sensor Metadata Format Specification Document

Sensor1: GrazAngle (degrees)

Sensor2: GA

Sensor3: *None*

Sensor4: GR (radians)



**Sensor-independent:
GrazingAngle (in degrees)**



Example Schema

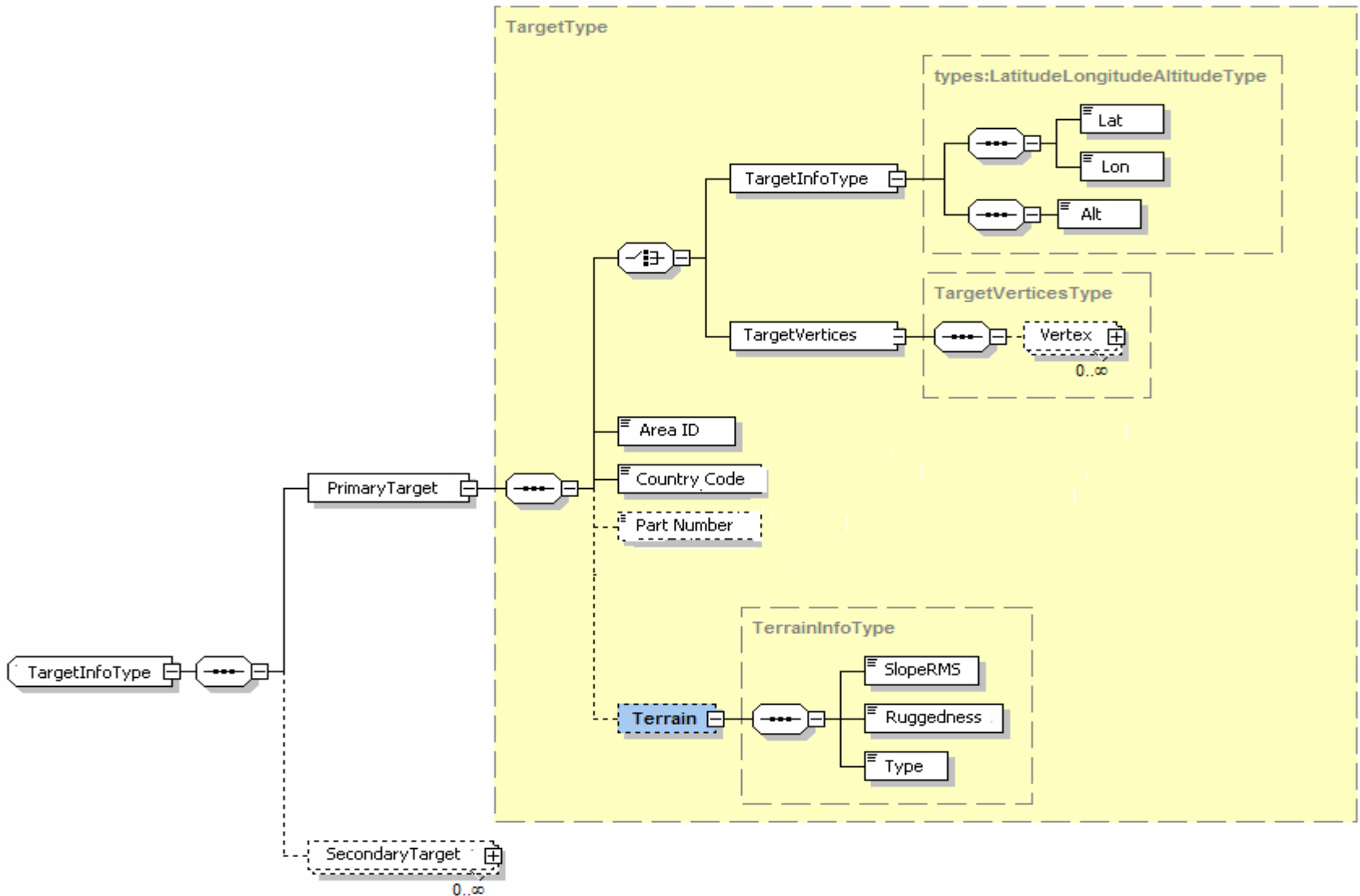



Recent Results

- Common Radar Dictionary of terms
- Metadata defined to enable repackaging of data between levels of data processing
- Metadata Model being developed
- Profile of Standards for Tools
 - Profile: subset of metadata for application
- Harmonization and mapping to TC211



Work with other GWG Focus Groups and ISO TC211

GWG Focus Group	Product	ISO Reference TC 211 in Blue	Work with the Group Includes:
NITFS Technical Board (NTB)		ISO/IEC 9973 Items Register	Utilize the NTB at Joint Interoperability Testing Center (JITC)
Motion Imagery Standards Board (MISB)	Motion Imagery Standards Profile	ISO/IEC 13818	Collaborate to determine if any overlapping requirements for the communities exist.
Community Sensor Model Working Group (CSMWG)	Community Sensor Model Sensor and Data models for imagery and Gridded Data	ISO TC 211 19130	Providing the Community Data Dictionary & Common SAR Sensor terminology ; Reviewing Synthetic Aperture Radar (SAR) Sensor Model Metadata Profile Supporting Precise Geopositioning
GEoint Reporting Focus Group (RFG)	Technical Advisory and coordination	n/a	Coordination when appropriate through GWG.
Geographic Portrayal Focus Group (PFG)	DGIWG Portrayal Roadmap	ISO 19117, <i>Geographic Information Portrayal</i> ISO 19135, <i>Procedures for Registration of Items of Geographic Information</i>	Use documentation provided by this group to gain context, enhance or clarify work
Metadata Focus Group (MFG)	National System for Geospatial Intelligence (NSG) Geospatial Core Metadata Profile (NGCMP) Version 1.0, Final Draft	ISO 19115:2003 <i>Geographic information – Metadata</i> ISO/DIS 19115-2 <i>Geographic information – Metadata – Part 2: Extensions for imagery and gridded data</i> ISO 19139:2007 <i>Geographic information - Metadata - XML schema implementation</i> ISO 19114:2003 - <i>Geographic information -- Quality evaluation procedure</i>	Working to expand the Specific Sensor & Vector Geospatial Dataset Reference for SAR UPHD Metadata items to the Metadata Profile.



Work with other GWG Focus Groups and ISO TC211

GWG Focus Group	Product	ISO Reference TC 211 in Blue	Work with the Group Includes:
Information Transfer & Services Architecture Focus Group (ITSA)	DGSWG Catalogue Service Profile Edition 1.0 Part 1: Concepts Technical Report	<p>ISO 19106:2003, <i>Geographic Information – Profiles</i> ISO 19115:2003, <i>Geographic Information – Metadata</i> ISO/DIS 19119, <i>Geographic Information – Services</i> ISO. 2004. ISO/TC 211/WG4/PT 19136 <i>Geographic information – Geography Markup language (GML). Committee Draft. 07 Feb 04.</i> ISO. 2006. ISO/TC 211. <i>Text for ISO/TS 19139 Geographic information...: Metadata – XML schema implementation. Draft. 18 August 2006.</i></p>	Follow guidance for catalogue metadata requirements from this group in all products developed.
Application Schemas for Feature Encoding Focus Group (ASFE)	GEOINT Structure Implementation Profile (GSIP) -- this work is being published in cooperation with the Metadata Focus Group	<p>ISO 19107:2003, <i>Geographic information – Spatial schema</i> ISO 19108:2005, <i>Geographic information – Temporal schema</i> ISO 19109:2005, <i>Geographic information – Rules for application schema</i> ISO 19115:2003, <i>Geographic information – Metadata</i> ISO 19115:2003/Cor. 1:2006, <i>Geographic information – Metadata – Corrigendum 1</i> ISO 19136:2007, <i>Geographic information – Geography Markup Language</i> ISO/TS 19139:2007, <i>Geographic information – Metadata – XML schema implementation</i></p>	Work with these groups to expand content beyond existing Specific Sensor and Vector Dataset Levels.



Enterprise Metadata Requirements

The MPWG, as a sub-group of the GWG, supports the NSG in its challenge to provide common geospatial services within a Service Oriented Architecture (SOA).

These interoperability requirements promote availability of geospatial information.

Examples:

- **Archival/Retrieval/Discovery**
- **Distribution**
- **Display**
- **Mensuration**
- **Product Generation**
- **Quality Metrics**
- **Exploration**



Future Work

- Incorporate interface standard profiles for additional products
- Document a taxonomy of product types
- Determine core metadata for each class of product.
- Define metadata requirements for functional capabilities
- Data prototyping



Summary

- MPWG functions as a subgroup of the GWG to develop data standards for the geospatial community
 - scientifically engineered metadata standards to support complex analysis
 - harmonizing efforts with ISO TC211 standards work



www.nga.mil



The MPWG

Metadata Profile Working Group (MPWG)

MPWG Purpose : “An enterprise that supports a seamless, unified common operating picture. Community-wide standards are enablers that provide a foundation for interoperable applications and compatible intelligence products that execute seamlessly across architectures.”

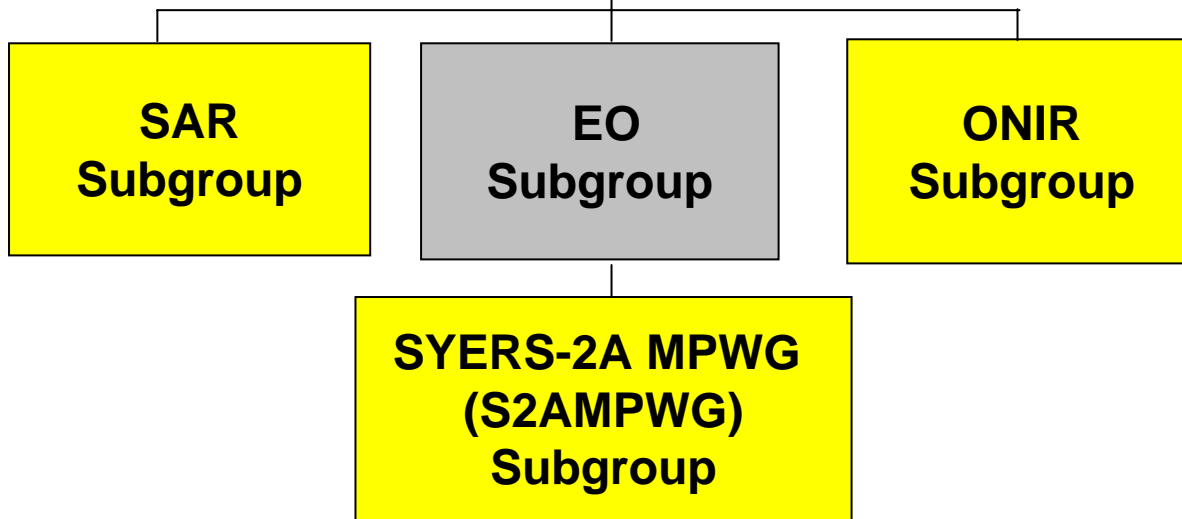

The MPWG enables interoperability across the NSG